

YORK[®] YCWE-E Series Water-Cooled Modular Scroll Chillers

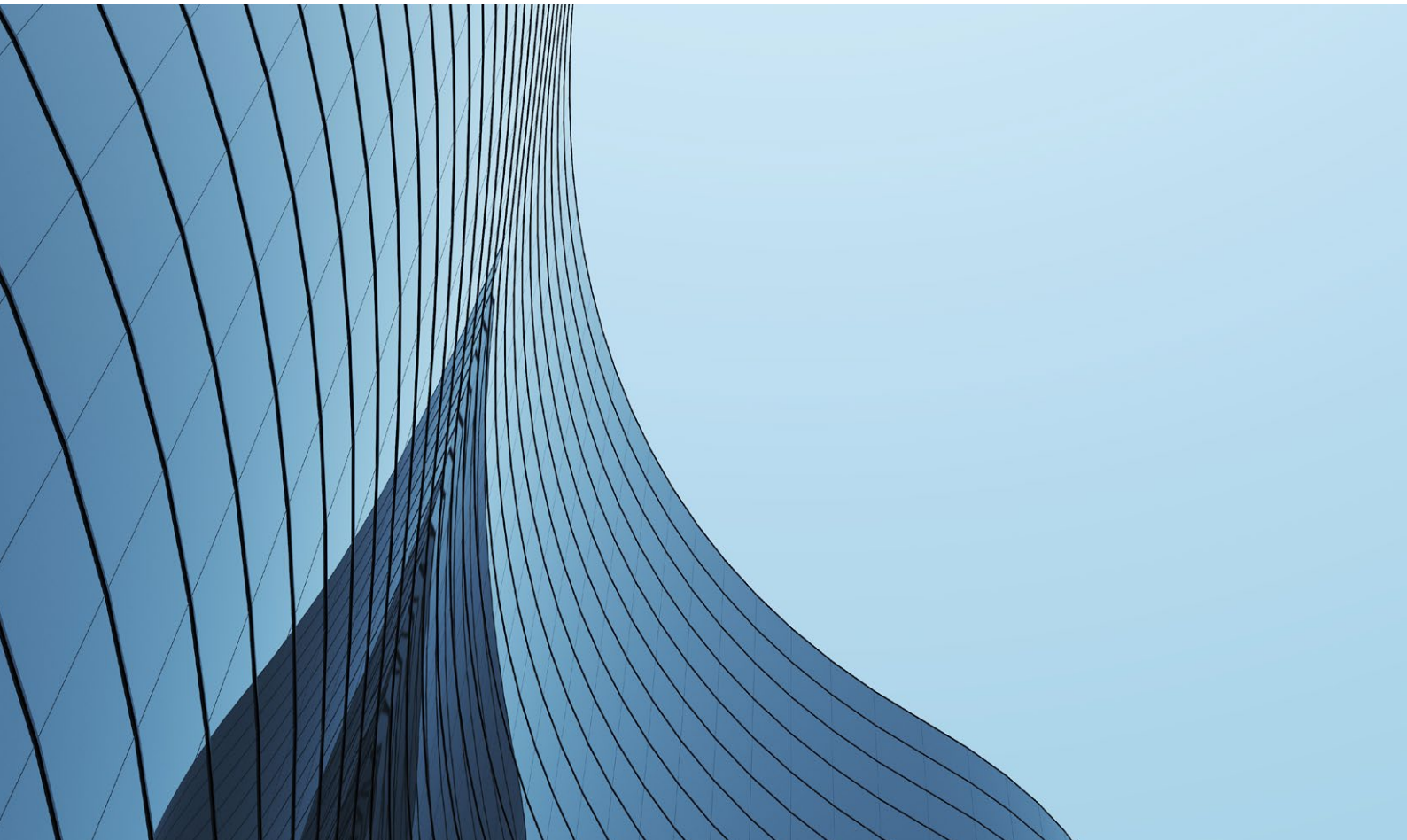

Water-Cooled Modular Scroll Chillers

The YORK® YCWE-E Series of Water-cooled Chillers are designed for energy-efficiency, reliability and sustainability. The YCWE-E Series is modular design – making it perfect for retrofits and new construction.

Exceptional Performance

The efficient and optimized design.

Smart Control

Controlled with the new-generation microcomputers, allows for easy connection to the building automation system.

Sustainability

The YORK® YCWE-E series uses R-410A, which is safe, available, and affordable and provides the best operating efficiency for YORK® chillers.

History of Reliability

When your reputation is at stake, count on efficient, reliable cooling and heating solutions from YORK® to lower costs and maximize uptime with dependability you can count-on. Have peace of mind in knowing that Johnson Controls has the largest service and preventative maintenance organization in the world.

Flexible Application

YCWE series provides a wide operation range to meet a variety of climates and locations without kits or add-ons.



Exceptional performance

A system design with parallel compressors

Such a design can effectively improve system unit performance, especially the performance part-load. The unit presents the highest efficiency under a partial load in the industry, and the annual operating cost is lower than that of competitive products.



New-type high-efficient condenser:

The condenser features a horizontal shell and tube heat exchanger where the refrigerant flows inside the shell and outside the tube have sufficient contact with the heat transfer surface. This provides a greater heat transfer coefficient, yielding an increased heat transfer efficiency.

Cross-flow water-side heat exchanger:

Heat is exchanged through the cross flow between the water side and the side of the two refrigerants. The water flow between any two sheets have contact with the two refrigerant systems at the same time, ensuring that the entire water flow always involves heat exchange, and to maximize the performance of a single unit under a partial load.

Multilevel energy regulation:

An individual unit can realize up to four levels of energy regulation (0-25%-50%-75%- 100%). Up to 8 units can be connected together with a wider range of energy regulation (up to 32 levels), a higher efficiency, and a better performance in saving energy.

Optimized control of the networking system:

The networking system automatically adjusts the operating state of the modules based on the load and activates multiple modules, to fully utilize the heat transfer area of the evaporator and the condenser, and to effectively improve the unit's performance, especially the performance under a part-load condition.

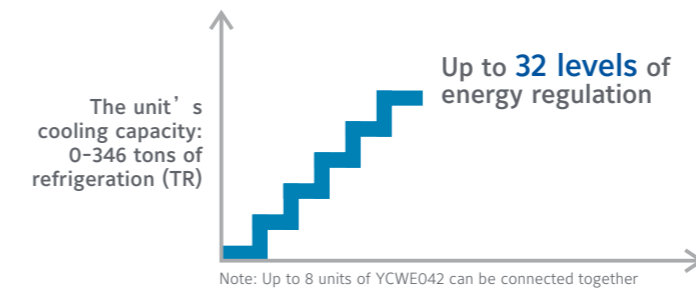

History of Reliability

Reliable design

Operating time of the compressors can be balanced: The operation status of each compressor is monitored in real time, and the operating time of each compressor is adjusted for balance, to extend the overall service life of the unit.



A multiple-compressor design:

Each unit involves multiple compressors. The failure of a single unit won't affect the normal operation of another unit. This ensures reliable operation of the entire system.

Mutual backup of multiple modules:

When multiple modules are running, the failure of a single module won't affect the operation of the entire system. Different modules are backup for each other. This can increase the reliability of system operation.

Reliable configuration

The R410A Scroll Compressor

The low-pressure chamber structure is designed with crankcase in a low-temperature area, and the motor is cooled by the refrigerant in the low-temperature return gas, this extends the motor's life.

Stainless steel evaporator

The asymmetric flow field design lowers the pressure drop on the water side and improves the antifreeze performance, to ensure the stable operation of the system.

Electronic expansion valve

The high-precision electronic expansion valves are used to make intelligent and adaptive adjustments to the flow of the refrigerant. This ensures that the flow of the refrigerant is precise and that the system's operation pressure and temperature are optimal.

Single-piece standard efficient all-copper filter

This can prevent dirt from entering the system, which prevents clogging.

Single-piece standard water flow switch

This can prevent the system from being froze-cracked due to poor water flow.

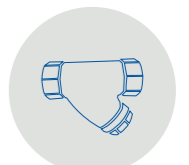
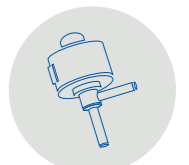
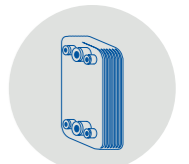

Multiple tests

Each model of the YCWE-E Series is subject to multiple reliability tests and analyses. The types of testing include: salt spray test for parts, transportation test, lifting test, electrical temperature rise test, rain proof test, and the modal analysis.

Smart control

Local control & communication

Two touch-screen controllers are provided for customers to choose from.

Standard central controller:

The controller is compact and beautiful with a user-friendly LCD touch-screen. It can be connected to up to 8 units. The range of the A/C system's cooling capacity can be expanded to 336 tons of refrigeration (TR).

Optiview LT™ controller:

The screen can display more parameters; the multilevel user permission setup ensures the safe operation of the A/C system; the controller supports software upgrade via USB, making it easy to maintain.

Remote control & communication

The system comes with the RS-485 interface, which by default supports Modbus protocol. BACnet protocol as available as an option.

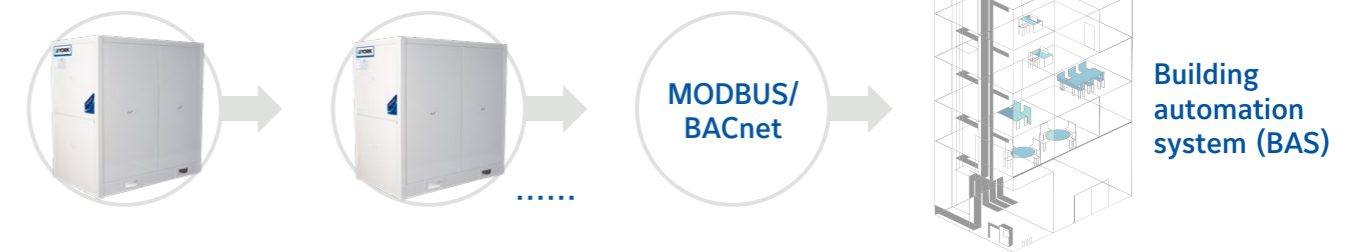

Interlocking

Variable flow primary pumping system:

Units are connected with interlocking piping. When the load requires additional capacity the controls turn on additional modules to meet the load requirement.

Remote interlocking:

The unit can provide the output of multiple control signals, including:

- Cooling tower control signal output
- Cooling water pump control signal output
- Cooling water three-way valve signal output
- Chilled water three-way valve signal output
- Module cooling water valve signal output
- Module chilled water valve signal output

Functions such as remote ON-OFF, remote heating-cooling switch, interlocking with the terminal thermostat switch, and remote alarming can be realized.

Schedule control

The system provides a calendar-like control mechanism to be automatically turned on or off at the specified time. The customer can set a time (day or week, except for holidays) to have the system automatically turned on or off.

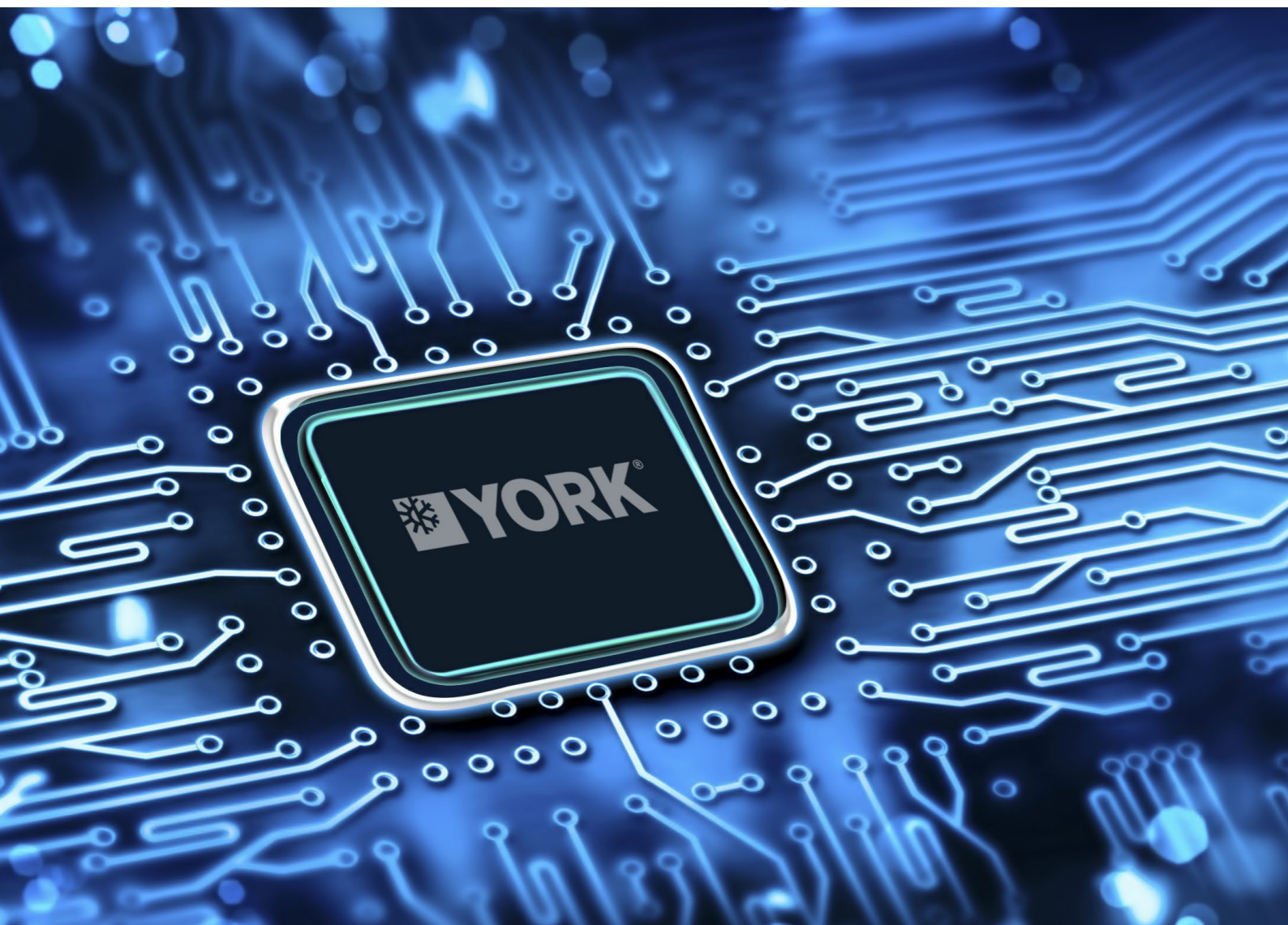

Sustainability

Protecting the atmosphere:

The system can reduce carbon emissions directly or indirectly and lower the carbon emission target, to protect the atmosphere, and to promote sustainable development.

Eco-friendly refrigerant:

The R410A is an eco-friendly hydrofluorocarbon (HFC) refrigerant, which does not contain chlorine, does not damage the ozone layer, and has a high efficiency.

Flexible application

Flexible configuration:

Each unit can be installed and operated separately. Multiple units can also be combined for optimal performance depending on the customer's need. Different models can be combined with up to 8 units connected.



Compact design:

The units can be moved using freight elevators to save the installation cost. In renovation applications there is no need to dismantle the existing building structures—reducing chiller replacement costs.

Product naming

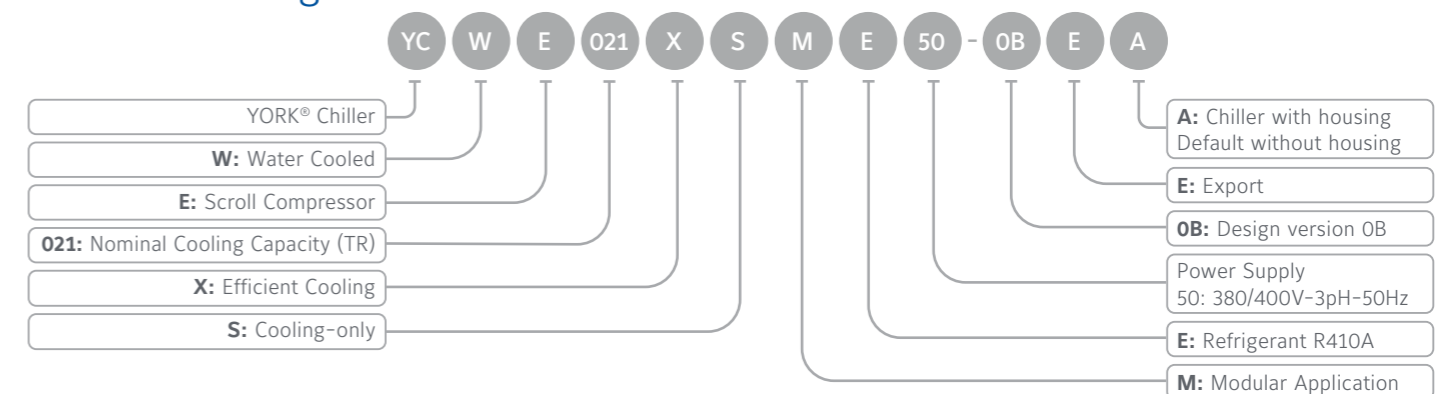

Parameter table

Model		YCWE021XSME	YCWE032XSME	YCWE042XSME	
Nominal Cooling Capacity	kW	76.2	114.2	151.9	
Input Power	kW	14.3	21.5	28.6	
COP	kW/kW	5.33	5.31	5.31	
Refrigerant	Type	R410A			
	Amount Injected(kg)	10.0	16.0	20.0	
Electrical Parameters	Power Supply	380/3/50 400/3/50			
	Rated Current	A	29.4	44.1	66.2
	Max. Current	A	46.4	69.6	104.4
Water Flow	Evaporator Side	m³/h	13.1	19.6	26.1
	Condenser Side		16.4	24.6	32.7
Water Pressure Drop	Evaporator Side	kPa	73.0	28.0	30.0
	Condenser Side		72.0	60.0	60.0
Compressor	Type	/	Fully Enclosed Vortex Type		
	Qty		2	3	4
	Output Power (Single)	kW	7.31	7.31	7.31
	Rated Current (Single)	A	14.70	14.70	14.70
Condenser	Type		Efficient Shell and Tube Heat Exchanger		
	Inlet/Outlet Pipe	mm	DN50	DN65	DN65
	Connection Style		Clamp Connection		
Evaporator	Type		Plate Heat Exchanger		
	Inlet/Outlet Pipe	mm	DN50	DN65	DN65
	Connection Style		Clamp Connection		
Measurements	H	mm	1230	1230	1230
	L		1480	1480	1480
	W		840	840	840
Unit Weight	Transportation Weight	kg	360	520	670
	Operation Weight		380	555	710

Notes:
 1. Each unit must be installed with a Y-shaped filter that comes with the unit at the water inlet of the evaporator.
 2. The cooling water and chilled water of the unit must be softened, to prevent the heat exchanger from scaling.
 3. Cooling capacities in kW given for 12°C/ 7°C chilled water entering / leaving temperature and 30°C/ 35°C cooling water entering / leaving temperature.



Dimensional Drawings

YCWE021XSME

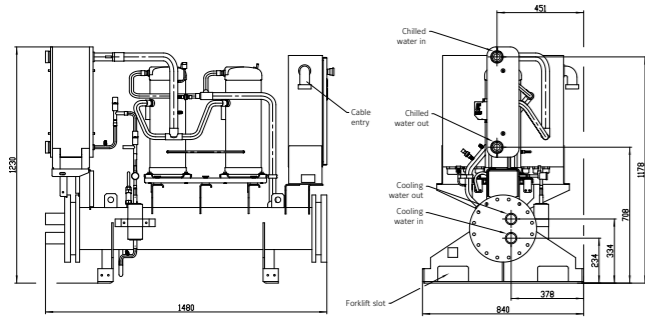

YCWE032XSME

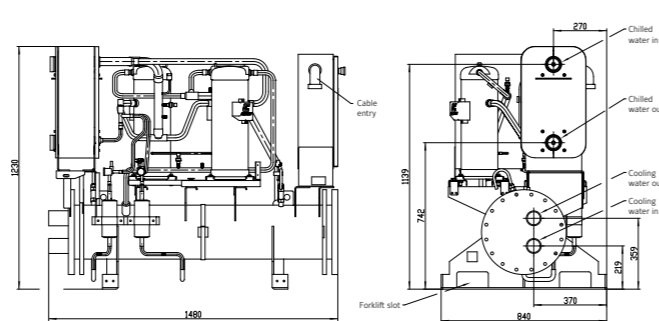

YCWE021XSME

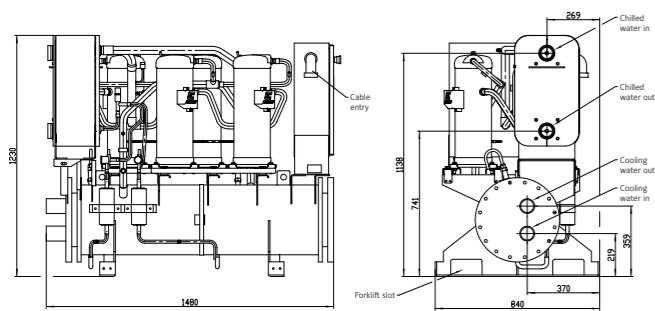

YCWE021XSME-A

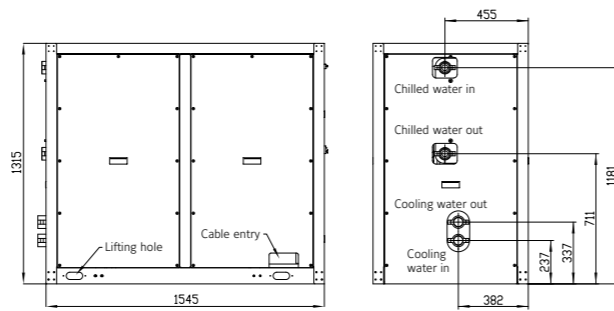

YCWE032XSME-A / YCWE042XSME-A

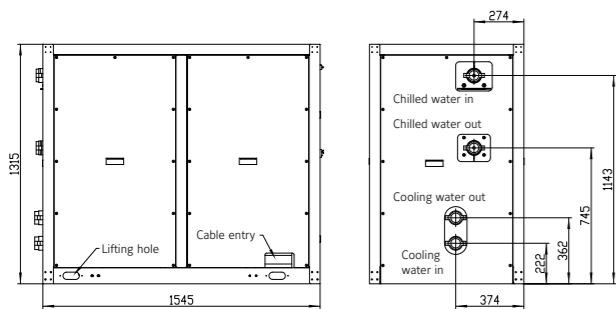

Dimensional Drawing for Standard Unit Connection

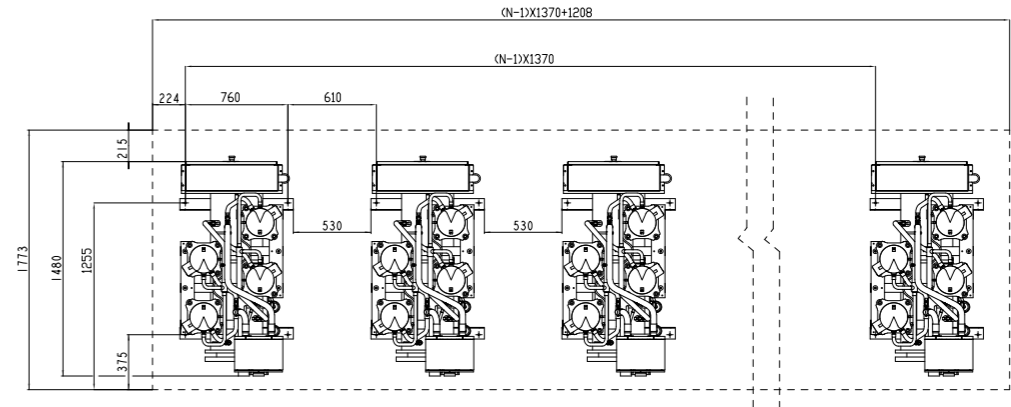

Dimensional Drawing for the Connection of Units with Optional Housing

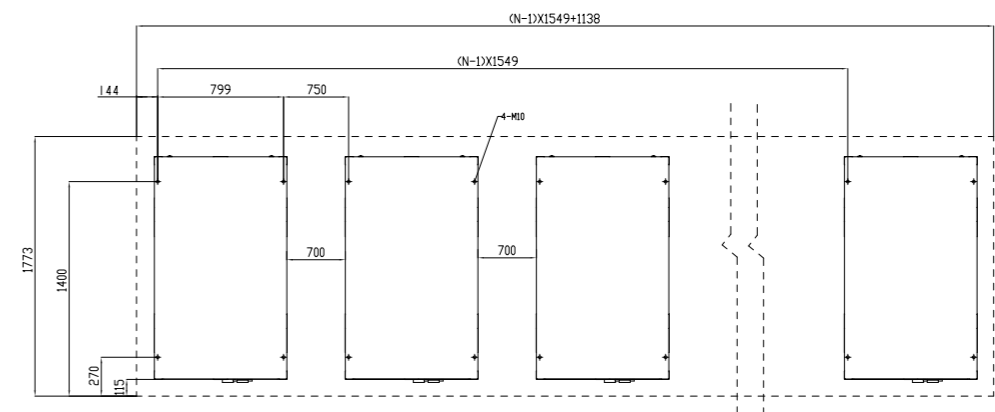

System operation range

Cooling Water		Chilled Water Outlet	
Inlet Temperature (°C)	In/Out Temperature Difference (°C)	Outlet Temperature (°C)	In/Out Temperature Difference (°C)
15-50	3.8-8	5-20	3.8-8

- Notes:
- When the temperature of water at the outlet on the heat source side of the system is lower than 5°C, there might be an alert for antifreeze protection. If the system needs to operate within this range, please contact the local Johnson Controls office.
 - Refer to Johnson Controls' selection software AECworks for the performance parameters of the system under different temperatures. Specific parameters should be based on the selection software.
 - If the system needs to operate under conditions where water needs to come out at a low temperature and an antifreeze needs to be added, please contact the local Johnson Controls office.

Water Supply Requirements for the Units

- Each unit must be installed with a Y-shaped filter that comes with the unit at the water inlet of the evaporator. The inlet pipe of the condenser must be installed with a water filter (30-mesh or above) by the user itself;
- The cooling water and chilled water of the unit must be softened. Please test the water quality of the water system strictly according to the requirements on the water quality of the unit's water system, to ensure that the quality of water within the unit meets the requirements in the table below:

Item	Unit	Allowed Value	Tendency	
			Corrosion	Scaling
PH (25°C)		7.5-8.0	○	
SO ₄ ⁻⁻	ppm	<100	○	
HCO ₃ ⁻ / SO ₄ ⁻⁻	ppm	> 1.0	○	
Cl ⁻	ppm	<50	○	
PO ₄	ppm	<2.0	○	
NH ₃	ppm	<0.5	○	
Free Chlorine	ppm	<0.5	○	
Fe ⁺⁺⁺	ppm	<0.5	○	
Mn ⁺⁺	ppm	<0.05	○	
CO ₂	ppm	<10	○	
H ₂ S	ppb	<50	○	
Temperature	°C	<65	○	○
Oxygen content	ppm	<0.1	○	
Total hardness	dH	4.8-8.5		○

Notes:
 1. The user needs to test the water quality on a regular basis before the installation of the unit and during its use.
 Please make sure that the water quality meets the requirements in the table above, to avoid serious scaling or corrosion of the heat exchanger;
 2. If the user can't ensure that the water quality meets the requirements, an intermediate heat exchanger needs to be added between the heat exchanger and the source water side.

Communication Line Requirements

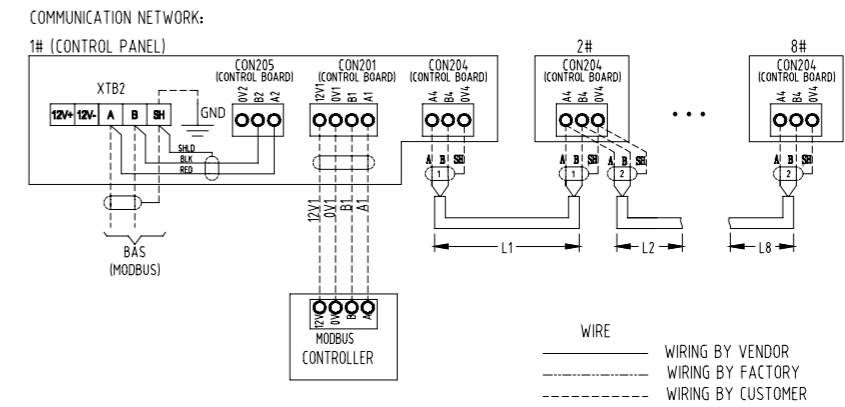
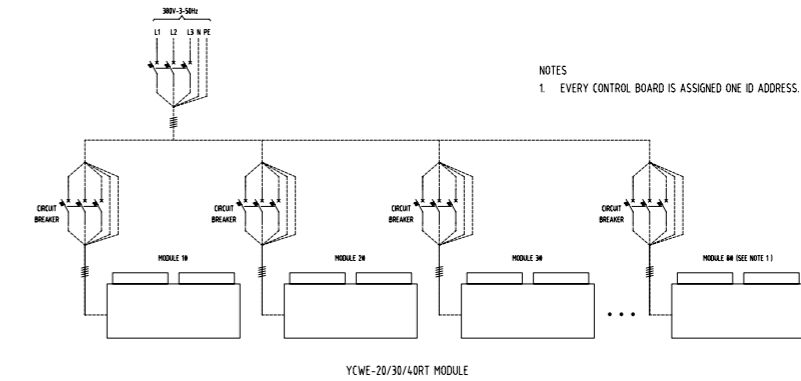

Water Pressure Drop Curves for the Unit

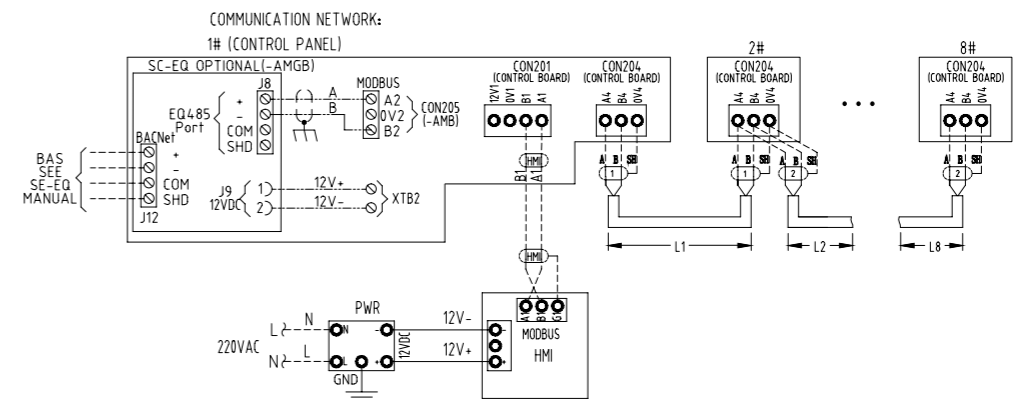
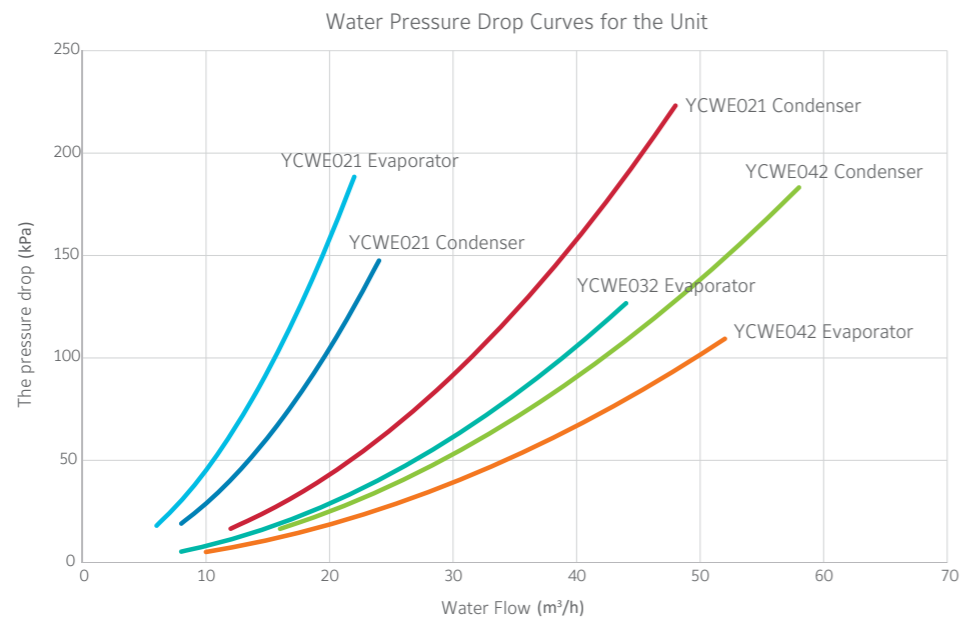

Telecommunications line requirement

The total length wires (From the wire control device to the last units)	L=L1+L2+...+L8(M)		
	L<100M	100M<L<500M	L>500M
The corresponding communication wire type	PVVPS 2×0.75mm ²	PVVPS 2×1mm ²	CONTACT JCI SERVICE

Notes:
 1. The length of the communication line between different modules: L = L1+L2+...+L8. Shielded twisted pairs are recommended for the communication lines. See Table 1 for details about the requirements on the communication lines.
 2. A communication address is assigned to each control panel.
 3. The maximum number of control panels in a network is 8. Different control panels should be set into different addresses; otherwise the control panels may be damaged.
 4. When setting the communication addresses, you should turn off the power supply to the control panels; otherwise, the control panels may be damaged.

About Johnson Controls Building Technologies and Solutions

Johnson Controls Building Technologies & Solutions is making the world safer, smarter and more sustainable – one building at a time. Our technology portfolio integrates every aspect of a building – whether security systems, energy management, fire suppression or HVACR – to ensure that we exceed customer expectations at all times.

We operate in more than 150 countries through our unmatched network of branches and distribution channels, helping building owners, operators, engineers and contractors enhance the full lifecycle of any facility. Our arsenal of brands includes some of the most trusted names in the industry, such as Tyco®, YORK®, *Metasys*®, Ruskin®, Frick®, PENN®, Sabroe®, Simplex® and Grinnell®.

For more information, visit www.johnsoncontrols.com or follow @JCI_Buildings on Twitter.

Australia (Sydney)

Tel: +61 (2) 9805 8300

Fax: +61 (2) 9247 7750

India (Mumbai)

Tel: +91 (22) 6683 7000

Fax: +91 (22) 6683 7002

Malaysia (Kuala Lumpur)

Tel: +60 (3) 7628 4300

Fax: +60 (3) 7874 1180

China (Shanghai)

Tel: +86 (21) 2285 7000

Fax: +86 (21) 2285 7599

Indonesia (Jakarta)

Tel: +62 (21) 5366 8500

Fax: +62 (21) 5366 8300

New Zealand (Auckland)

Tel: +64 (9) 635 0880

Fax: +64 (9) 633 1862

China (Hong Kong)

Tel: +852 2885 4451

Fax: +852 2885 7760

Japan (Tokyo)

Tel: +81 (3) 5738 6100

Fax: +81 (3) 5738 6298

Singapore

Tel: +65 6748 0202

Fax: +65 6743 4420

China (Macau)

Tel: +853 2875 1820

Fax: +853 2875 1825

Korea (Seoul)

Tel: +822 1588 9117

Fax: +822 6009 9014

Thailand (Bangkok)

Tel: +66 (2) 794 0101

Fax: +66 (2) 717 1327-8